



**LEAPTON**  
SOLAR

Monofacial

Bifacial

# LP182\*210-M-66-NH N-Type TOPCon

Rated Power 610-630W

**FIBERGLASS FRAME**

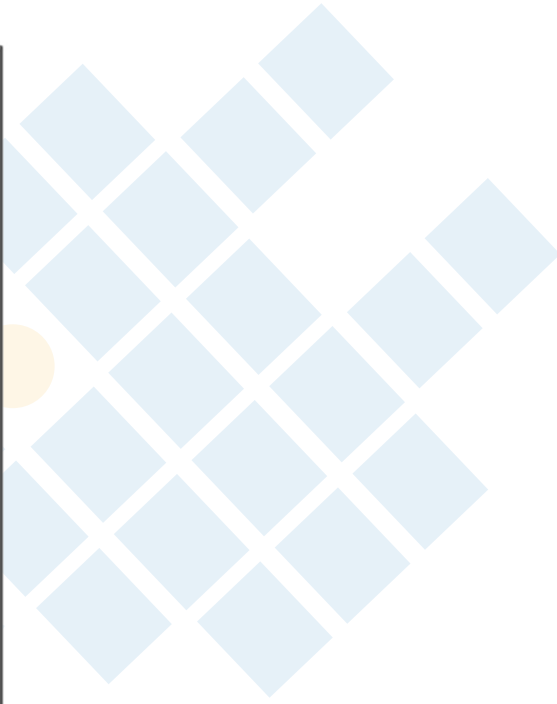

**N-Type 182\*210mm Cell**  
Adopting the 182\*210mm N-Type TOPCon battery cells with the highest efficiency.



**Low Light Features**  
Higher performance under low light environment.



**Superb corrosion resistance**  
With fiberglass frame, resistant to salt spray and ammonia. Can be installed in any environment.



**Maintains its shape**  
Fiberglass has highly resistant to deformation, even in extreme conditions like high temperature and humidity.



**Higher Output Power**  
Module adopts 132 pcs of 182\*210mm half cells, the maximum power can reach 630W.



**PID Protection**  
Ensure the attenuation probability caused by PID phenomenon is minimized.



**Harsh Environmental Adaptability**  
Strict salt spray and ammonia corrosion test by TUV Nord.



**Load Capacity**  
Mechanical load tests including wind load 2400 Pa and snow load 5400 Pa done by TUV Nord.

Leapton N-Type Linear Power Warranty Industry Warranty

0.4% Annual Degradation over 30 years

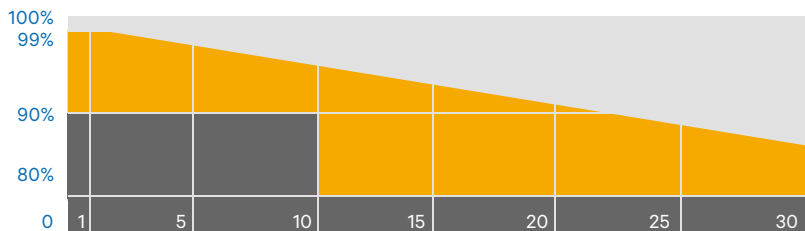

Headquarter : Leapton Energy Co., Ltd.

Tosei Bldg. 6F, 1-2-1 Aioi-cho, Chuo-ku Kobe-shi, Hyogo, 650-0025, Japan

+81-78-382-3182

www.leaptonenergy.jp

Manufacturer : Leapton Solar (Changshu) Co., Ltd.

No.9, Sunshine Avenue, Changshu City, Jiangsu, China

+86-512-88800068

info@leaptonenergy.com

www.leaptonpv.com

## MECHANICAL DIAGRAMS

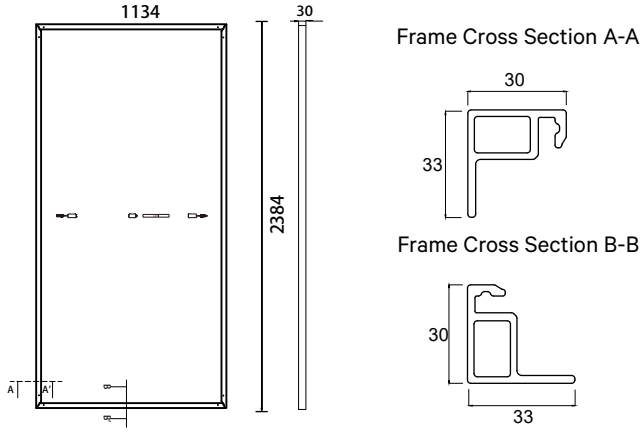

## SPECIFICATIONS

Weight	30.5kg
Dimensions	2384mm*1134mm*30mm
Cell Dimensions	182*210mm
Cell Amount	66*2 pcs
Maximum System Voltage	1500V
Junction Box	IP68
Front glass	3.2 mm heat strengthened glass with anti-reflective coating
Frame	Fiberglass
Cable	4mm <sup>2</sup> , N 1400mm/P 1400mm for Horizontal installation 4mm <sup>2</sup> , N 300mm/P 300mm for Vertical installation
Connector	MC4 compatible
Ex-tarifario	EX 589

## ELECTRICAL PARAMETERS AT STC

Power	610W	615W	620W	625W	630W
Open Circuit Voltage	49.05V	49.35V	49.55V	49.75V	49.95V
Short Circuit Current	15.84A	15.88A	15.93A	16.00A	16.05A
Maximum Power Voltage	40.66V	40.86V	41.06V	41.26V	41.46V
Maximum Power Current	15.00A	15.05A	15.10A	15.15A	15.20A
Module Efficiency	22.56%	22.75%	22.93%	23.12%	23.30%

\* Under Standard Test Conditions (STC) of irradiance of 1000 W/m<sup>2</sup>, spectrum AM 1.5 and cell temperature of 25°C.

## ELECTRICAL PARAMETERS AT NMOT

Power	465W	469W	472W	476W	480W
Open Circuit Voltage	46.51V	46.81V	47.01V	47.21V	47.41V
Short Circuit Current	12.78A	12.81A	12.84A	12.88A	12.93A
Maximum Power Voltage	38.20V	38.40V	38.60V	38.80V	39.00V
Maximum Power Current	12.17A	12.21A	12.23A	12.27A	12.31A

\* Under Nominal Module Operating Temperature (NMOT), irradiance of 800 W/m<sup>2</sup>, spectrum AM 1.5, ambient temperature 20°C, wind speed 1 m/s.

## TEMPERATURE CHARACTERISTICS

NMOT	41±3°C	Temp Coefficient of ISC	+0.046%/°C
Temp Coefficient of VOC	-0.25%/°C	Temp Coefficient of Pmax	-0.30%/°C

## PACKING CONFIGURATION

Modules/Pallet	36 Pieces	Modules/40'Container	720 Pieces
Packing Description	20 Pallets, Total=(36+36)x10=720 Pieces		

## CHARACTERISTICS

LP182\*210-M-66-NH-610W

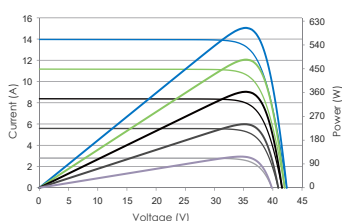

LP182\*210-M-66-NH-610W

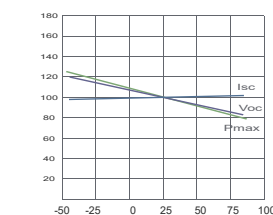

## MAXIMUM RATING

Output Tolerance	0~+5W
Operating Temperature	-40°C~+85°C
Wind Load/Snow Load	2400pa/5400pa
Fuse Current	25A



Headquarter : Leapton Energy Co., Ltd.

📍 Tosei Bldg. 6F, 1-2-1 Aioi-cho, Chuo-ku Kobe-shi, Hyogo, 650-0025, Japan

Manufacturer : Leapton Solar (Changshu) Co., Ltd.

📍 No.9, Sunshine Avenue, Changshu City, Jiangsu, China

☎ +81-78-382-3182

🌐 www.leaptonenergy.jp

☎ +86-512-88800068

✉ info@leaptonenergy.com

🌐 www.leaptonpv.com